

# Mounting instructions

2024-04-29 38-155900n



|   |  |  |   |
|---|--|--|---|
|  | Montageanleitung<br>Monteringvejledning<br>Asennusohje<br>Instructions de montage                        | Mounting instruction<br>Istruzioni di montaggio<br>取付要領書<br>Montāžas instrukcija           | Monteringsanvisning<br>Instrukcja montażowa<br>Указания по монтажу<br>Monteringsanvisning             |
|  | Demontage<br>Afmontering<br>Purkaminen<br>Démontage  | Dismantling<br>Smantellamento<br>解体<br>Demontāža   | Demontering<br>Demontaž<br>Демонтаж<br>Demontering  |
|  | Visuelle Kontrolle<br>Visuel kontrol<br>Silmämääräinen tarkastus<br>Contrôle visuel                      | Visual check<br>Controllo visivo<br>目視確認<br>Vizuālā pārbaude                               | Visuell kontroll<br>Kontrola wzrokowa<br>Визуальный контроль<br>Visuell kontroll                      |
|  | Anleitungen des Herstellers<br>Producentens anvisning<br>Valmistajan ohjeet<br>Instructions du fabricant | Manufacturer's instruction<br>Istruzioni del produttore<br>メーカーの指示。<br>Ražotāja norādījumi | Produsentens anvisning<br>Wskazówki producenta<br>инструкции производителя<br>Tillverkarens anvisning |

## DE Allgemein

Die Montage darf nur von ausgebildetem und kompetentem Fachpersonal durchgeführt werden und muß in einer befugten Werkstatt erfolgen, die über erforderliche Werkzeuge und Ausrüstungen verfügt, und in der Zugänglichkeit und Sicherheit gegeben sind. Alle Teile vor der Montage identifizieren. Anweisungen befolgen.

Empfohlene Einstellungen nicht ändern. Übergeben Sie dem Kunden alle Anweisungen und Instruktionen zur Aufbewahrung im Fahrzeug für künftige Service- und Wartungsarbeiten. Befolgen Sie die Anweisungen des LKW-Herstellers

## DK Generelt

Monteringen skal foretages af uddannet og kompetent personale og ske på autoriseret værksted, der råder over det nødvendige værktøj og udstyr, og hvor der sikres tilgængelighed og sikkerhed. Kontroller at alle dele er til stede inden montering. Følg anvisningerne.

Anbefalede indstillinger må ikke ændres. Giv kunden alle anvisninger og instruktioner, så de kan lægges i bilen til brug ved fremtidig service og vedligeholdelse.

Følg lastbilfabrikantens anvisninger

## FI Yleistä

Laitteisto on asennettava valtuutetussa korjaamossa, jonka koulutetulla ja ammattitaitoisella henkilökunnalla on käytössään tarvittavat työkalut ja varusteet ja jossa on turvalliset työskentelyolot. Tunnista kaikki osat ennen asennusta. Noudata ohjeita.

Älä muuta suositeltuja säätöjä. Luovuta kaikki ohjeet asiakkaalle säilytettäväksi autossa tulevia huoltoja ja kunnossapittoa varten.

Noudata ajoneuvon valmistajan ohjeita

## FR Généralités

Le montage doit être effectué par des personnes possédant la compétence et la formation requises, dans un atelier autorisé disposant des outils et équipements nécessaires et où l'accessibilité et la sécurité peuvent être assurées. Identifier tous les composants avant de procéder au montage. Suivre les instructions.

Ne pas modifier les réglages recommandés. Toutes les informations et toutes les instructions doivent être remises au client afin d'être conservées dans le véhicule et utilisées pour les opérations d'entretien futures.

Se conformer également aux instructions du constructeur du camion

## GB General

Installation work should be carried out by trained and skilled staff. It should be performed at an authorised workshop where the required tools and equipment are available and where provisions can be made for accessibility and safety. Identify all components prior to installation. Follow the instructions.

Do not alter the recommended settings. Give the customer all directives and instructions so that these can be kept in the vehicle for future service and maintenance.

Follow the instructions of the vehicle manufacturer

## IT Generalità

Il montaggio deve essere effettuato da personale competente e dotato della formazione richiesta, in una officina autorizzata, in possesso delle necessarie attrezzature e dove accessibilità e sicurezza possano essere garantite. Identificare tutti i componenti prima di procedere al montaggio. Seguire le istruzioni.

Non modificarne le raccomandazioni. Tutte le informazioni e tutte le istruzioni devono essere trasmesse al cliente e conservate a corredo del veicolo per essere utilizzate nelle operazioni di successiva manutenzione.

Attenersi altresì alle istruzioni del costruttore del veicolo.

## JP 一般注意事項

組立は、研修を受け技量のある従業員が行うようにしてください。また、必要な工具や設備が整い、至便性や安全性の行き届いた、認可を受けたサービス工場で行ってください。

組立前に、全ての部品を確認してください。説明に従ってください。

推奨の設定を変更しないでください。説明書や指示書はすべて顧客に渡し、顧客が車内に保管して将来のサービスや点検時に参照できるようにしてください。

トラックメーカーの指示に従ってください。

## LV Vispārēji norādījumi

Uzstādīšanas darbi jāveic trenētām un apmācītām personām. Tie jāizpilda autorizētā darbnīcā, kur ir pieejami nepieciešamie darbarīki un aprīkojums un kur ir nepieciešamie nosacījumi, lai nodrošinātu piekļuvi un drošību. Pirms montāžas identificējiet visas detaļas. Sekojiet norādījumiem. Neizmainiet ieteiktos iestatījumus. Visus norādījumus un instrukcijas izsniedziet klientam, lai tās tiktu uzglabātas automobilī un būtu pieejamas servisa un apkopes gadījumos. Ievērojiet automašīnas izgatavotāja instrukcijas.

## **NO** Generelt

Monteringen skal utføres av kompetent personell med nød-vendig opplæring, og skal skje på autorisert verksted hvor nødvendig verktøy og utstyr er tilgjengelig og sikkerheten kan ivaretas. Identifiser alle deler før montering. Følg anvisningene.

Ikke foreta endringer av anbefalte innstillinger. Overlever alle anvisninger og instruksjoner til kunden for oppbevaring i kjøretøyet for fremtidig service og vedlikehold.

Følg lastebilprodusentens anvisninger

## **PL** Informacje ogólne

Montaż powinien być wykonywany wyłącznie przez przeszkolonych i kompetentnych pracowników. Powinien być wykonany w autoryzowanym punkcie obsługi technicznej, gdzie znajdują się wymagane narzędzia i wyposażenie oraz gdzie może być zapewniony odpowiedni dostęp i bezpieczeństwo. Zapoznaj się z poszczególnymi częściami przed przystąpieniem do montażu. Stosuj się do instrukcji. Nie zmieniaj zalecanych ustawień. Wszystkie wskazówki i instrukcje należy przekazać klientowi w celu przechowywania ich w pojeździe i wykorzystywania przy okazji przyszłych czynności serwisowych i konserwacyjnych.

Postępuj zgodnie z instrukcją producenta pojazdu.

## **RU** Общая информация

Монтажные работы должны проводиться обученным и квалифицированным персоналом. Работы должны проводиться в специализированной мастерской, где имеются все необходимые инструменты и оборудование, и где созданы все условия для соблюдения правил безопасности. Перед сборкой проверьте наличие всех деталей.

Соблюдайте инструкции. Также выполняйте инструкции производителя грузовых автомобилей. Не изменяйте рекомендованные параметры.

Ознакомьте заказчика с инструкциями для того, чтобы он соблюдал их при эксплуатации и обслуживании

## **SE** Allmänt

Monteringen skall utföras av utbildad och kompetent personal och ske på auktoriserad verkstad där erforderliga verktyg och utrustning finns och där åtkomlighet och säkerhet kan tillgodoses. Identifiera alla delar före montering. Följ anvisningarna.

Ändra ej rekommenderade inställningar. Lämna alla anvisningar och instruktioner till kunden att förvaras i fordonet för framtida service och underhåll.

Följ lastvagnstillverkarens anvisningar

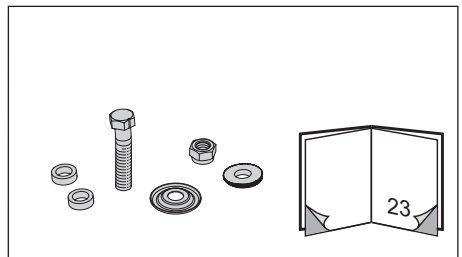
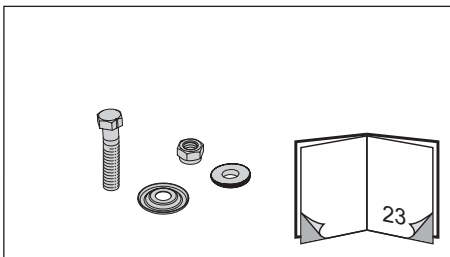
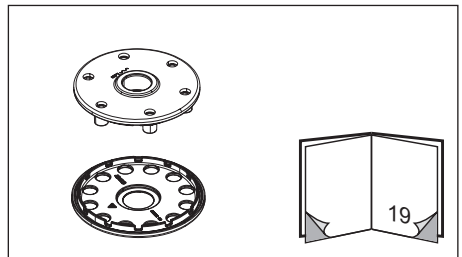
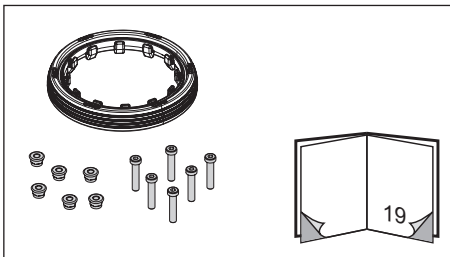
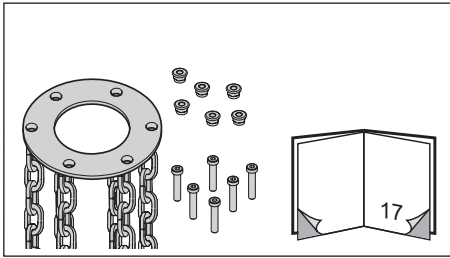
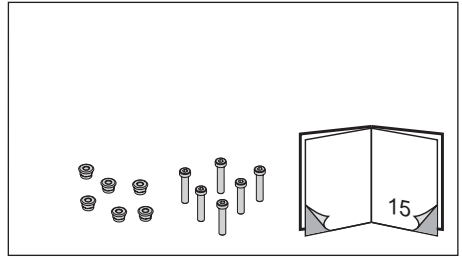
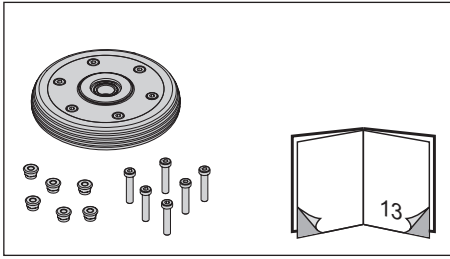
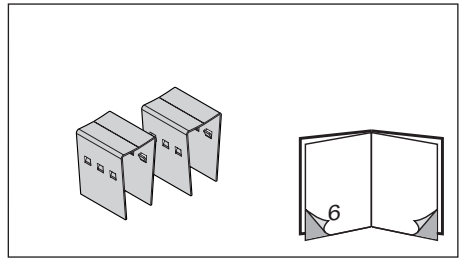
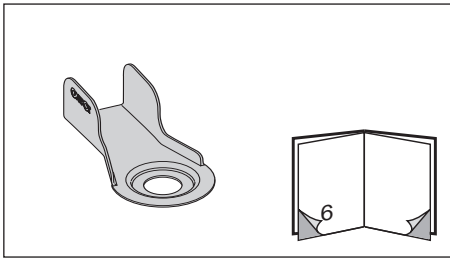

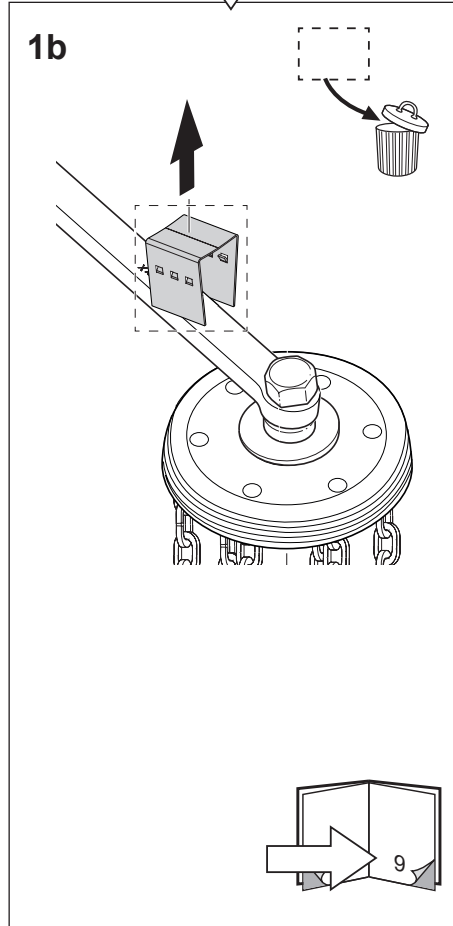
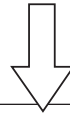
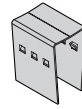
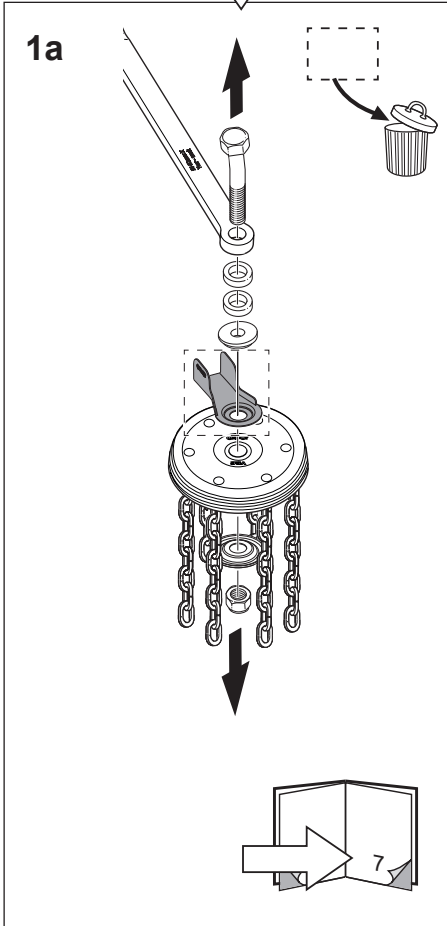
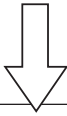

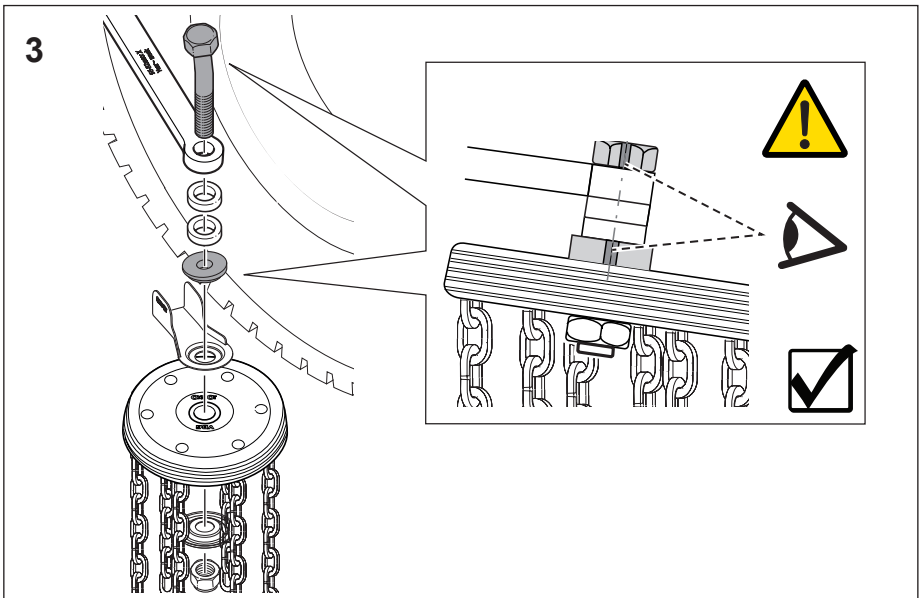
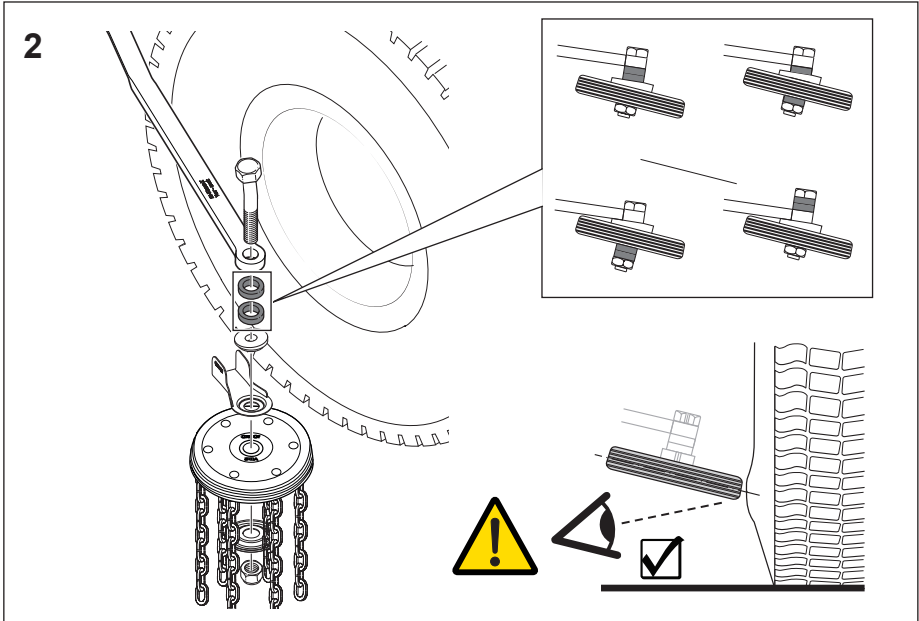

4

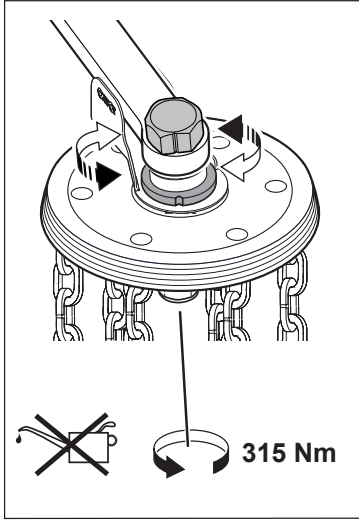

$10^{\circ} \pm 5^{\circ}$

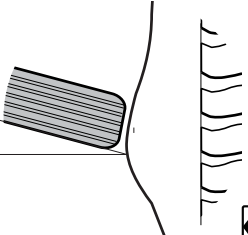

$0^{\circ} \pm 1^{\circ}$

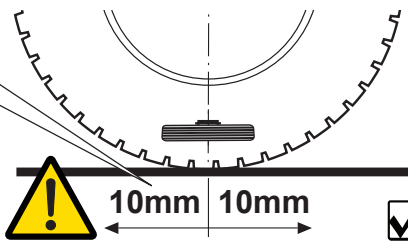
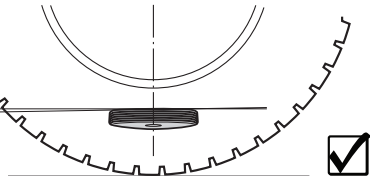

10mm 10mm



5.

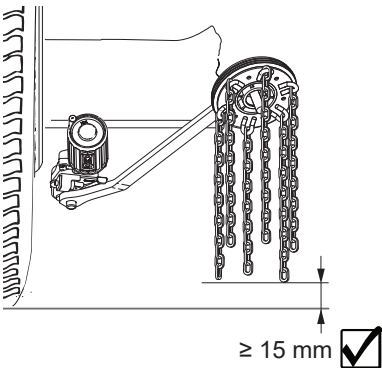

$\geq 15 \text{ mm}$

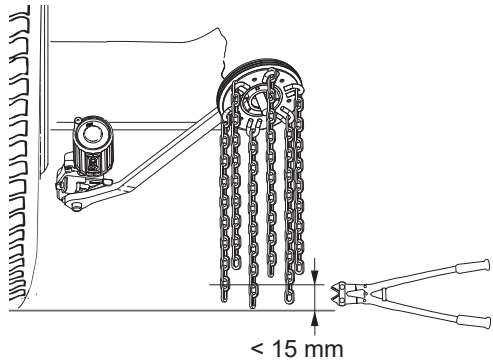

$< 15 \text{ mm}$



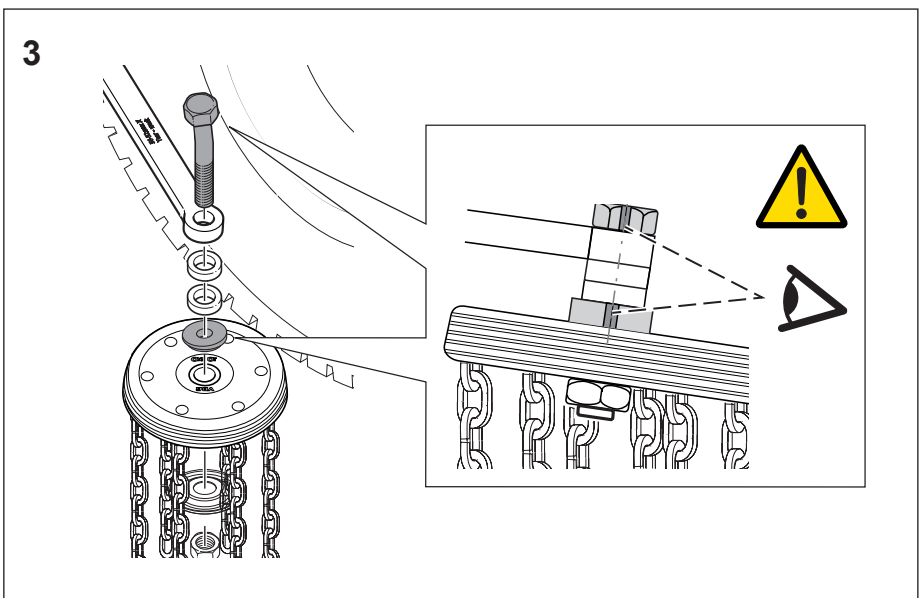
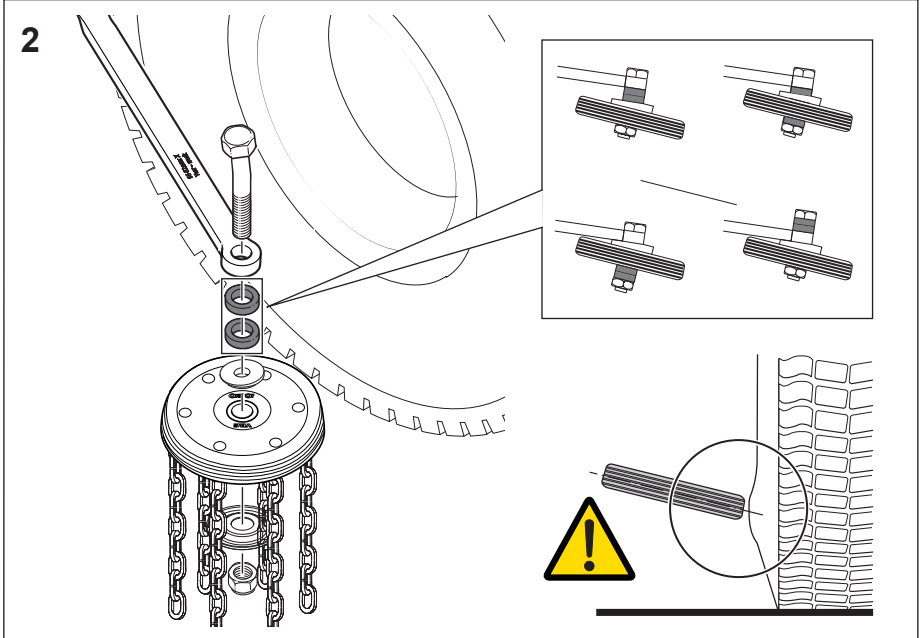
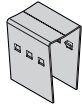

4

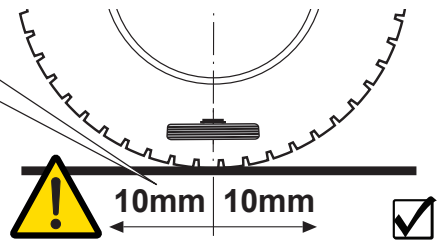
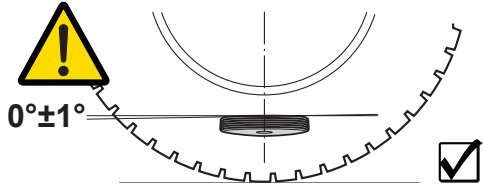
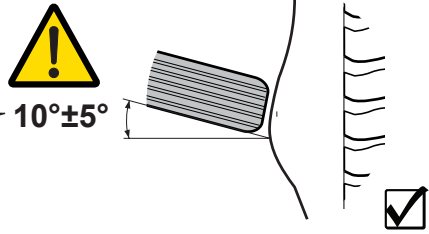
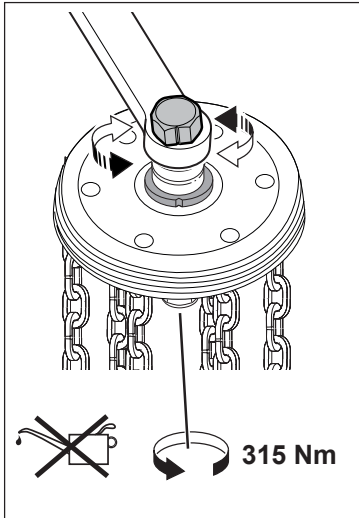

5.

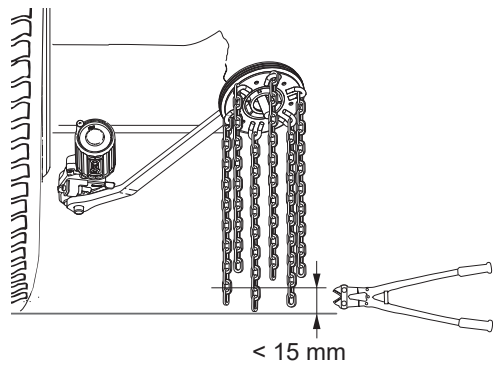
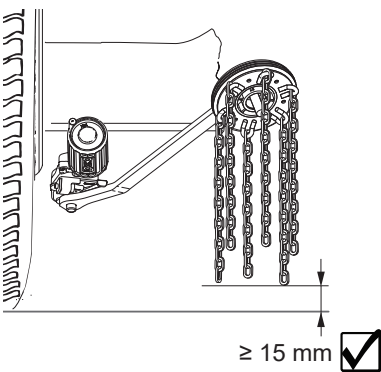

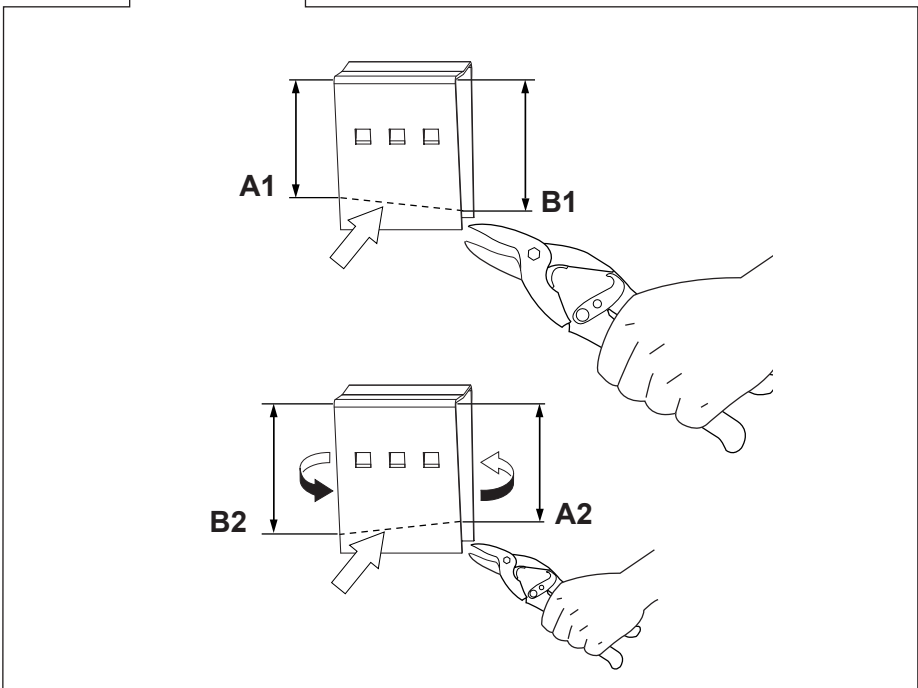
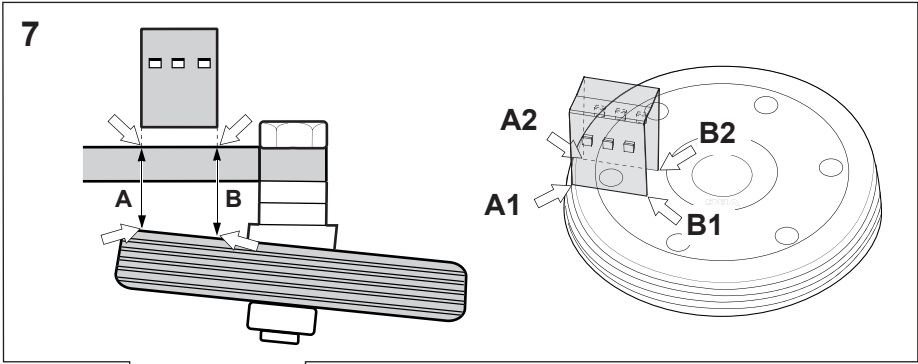
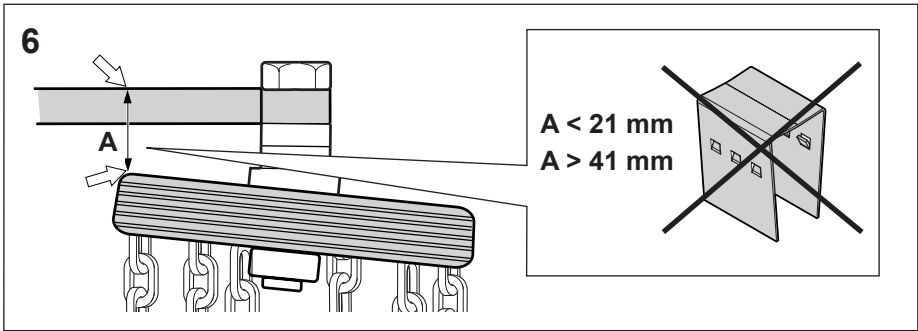

8

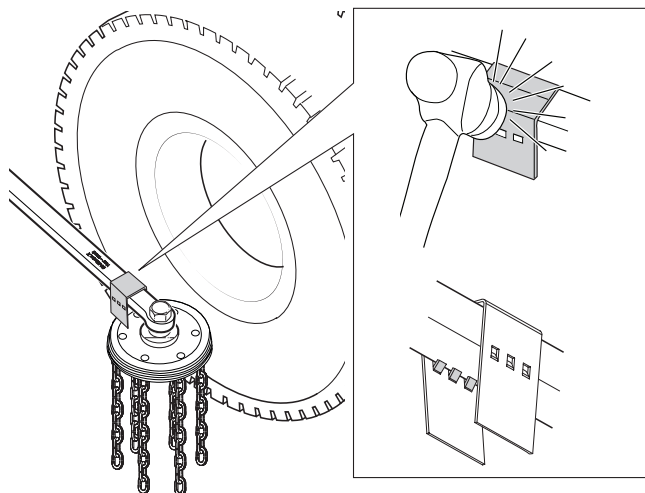
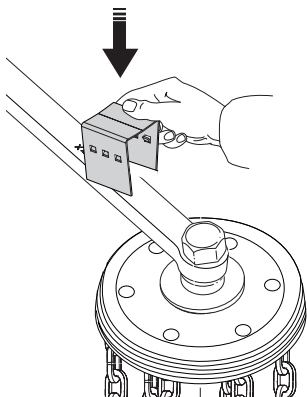

9

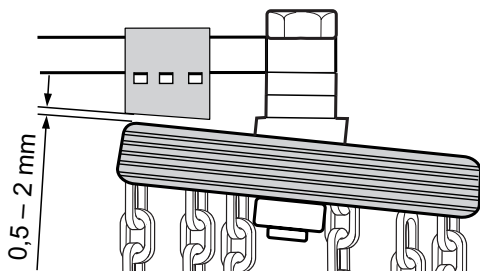

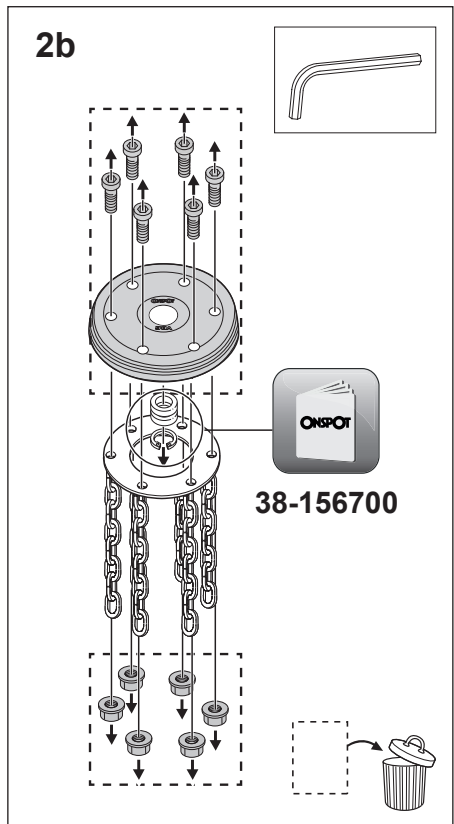
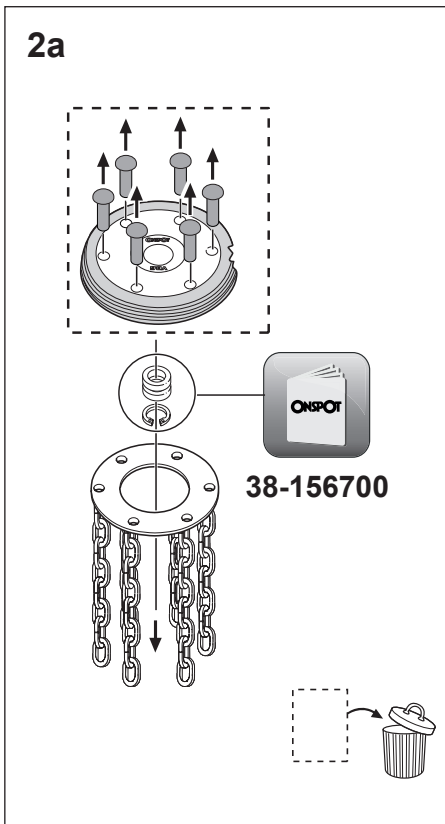
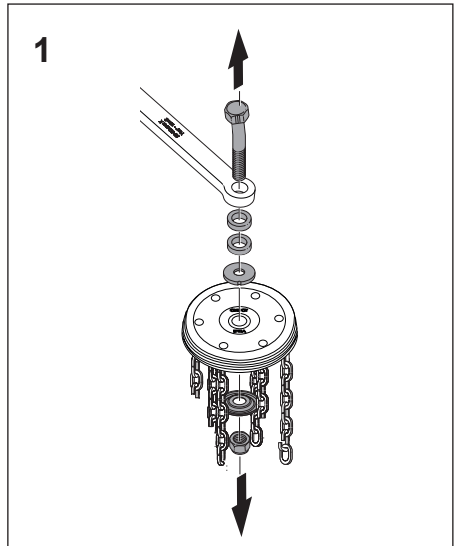
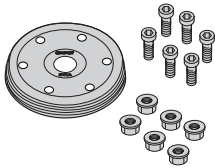

3

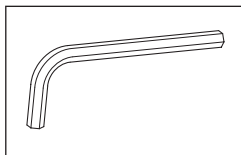
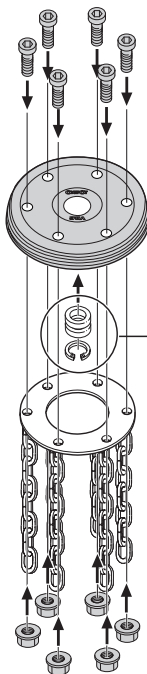

38-156700

20 Nm

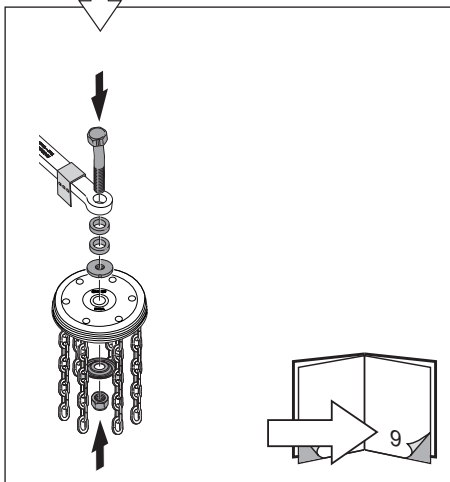
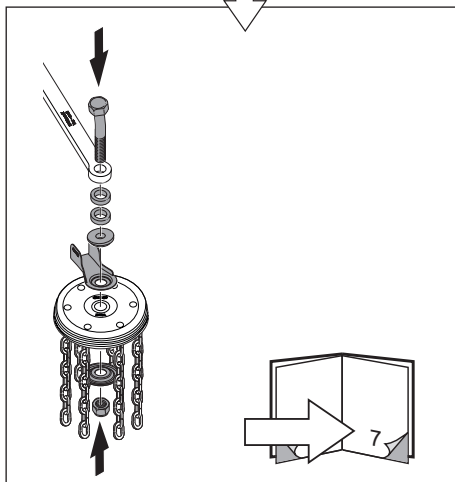
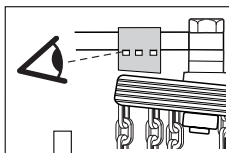
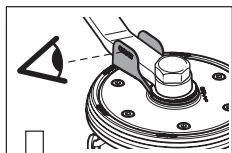

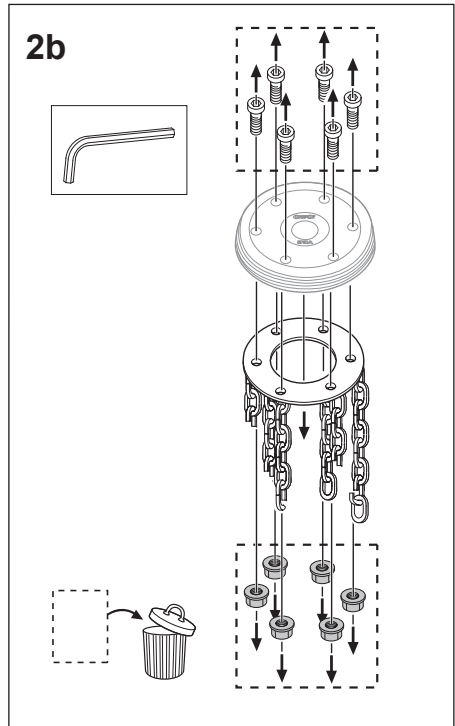
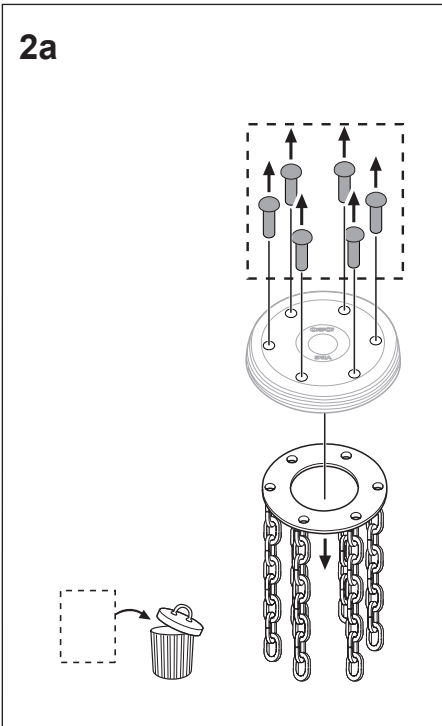
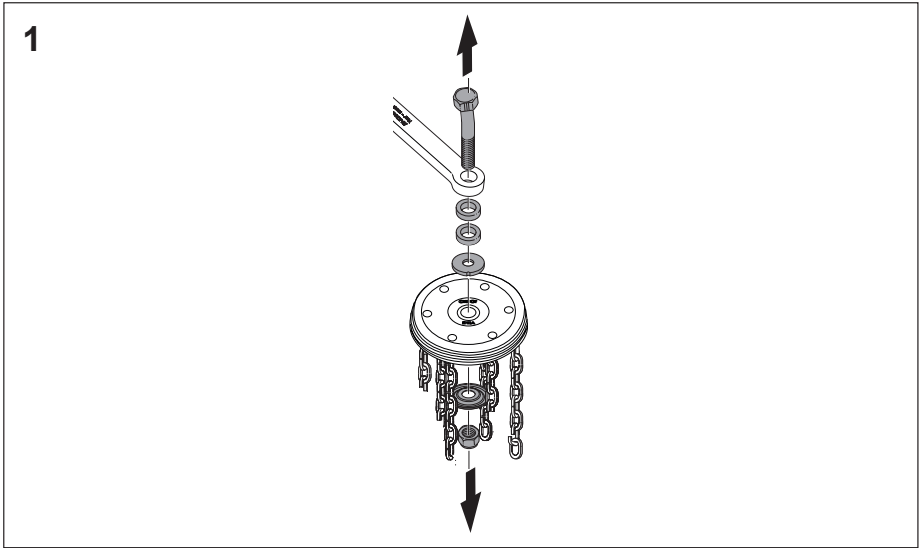
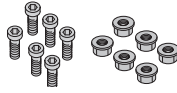

3

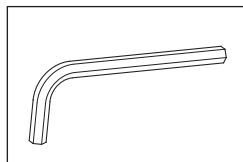
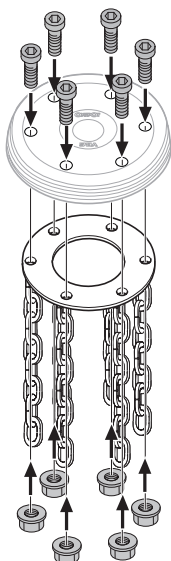

20 Nm

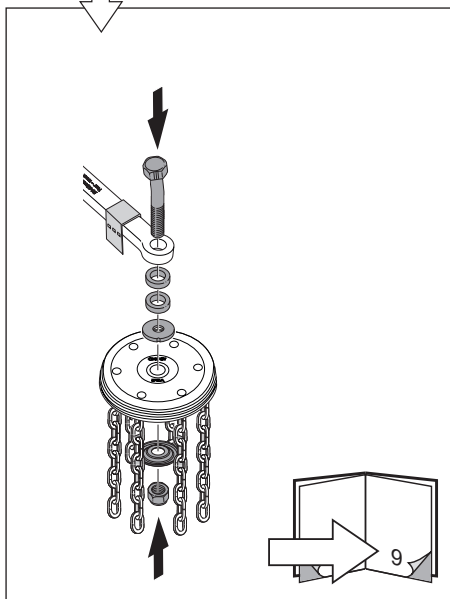
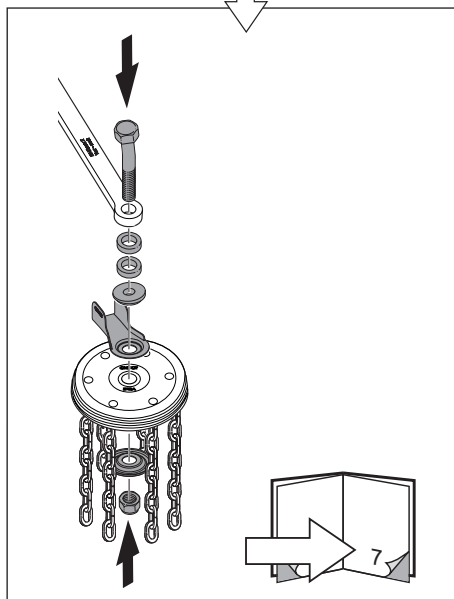
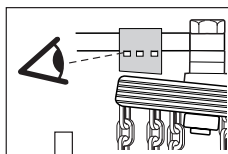
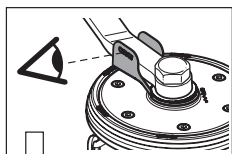

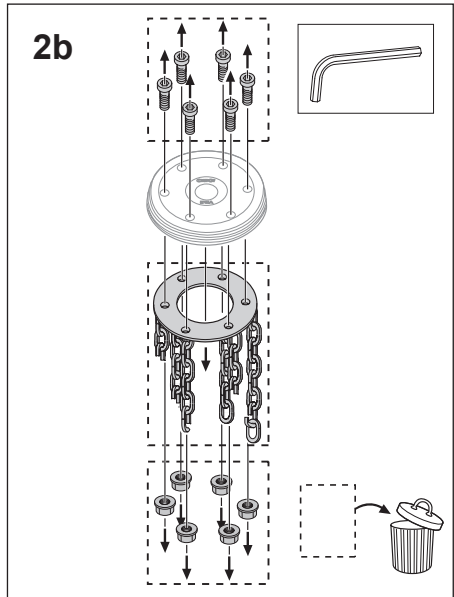
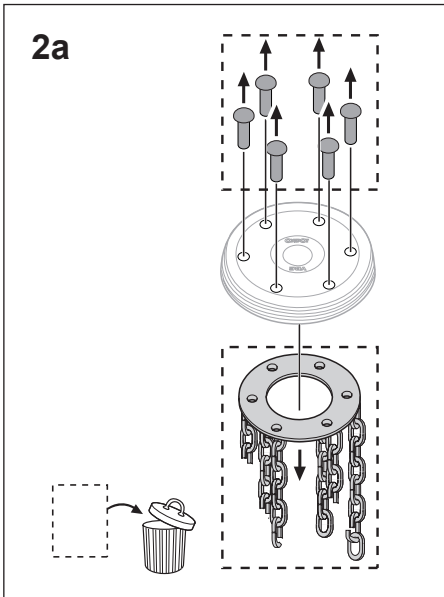
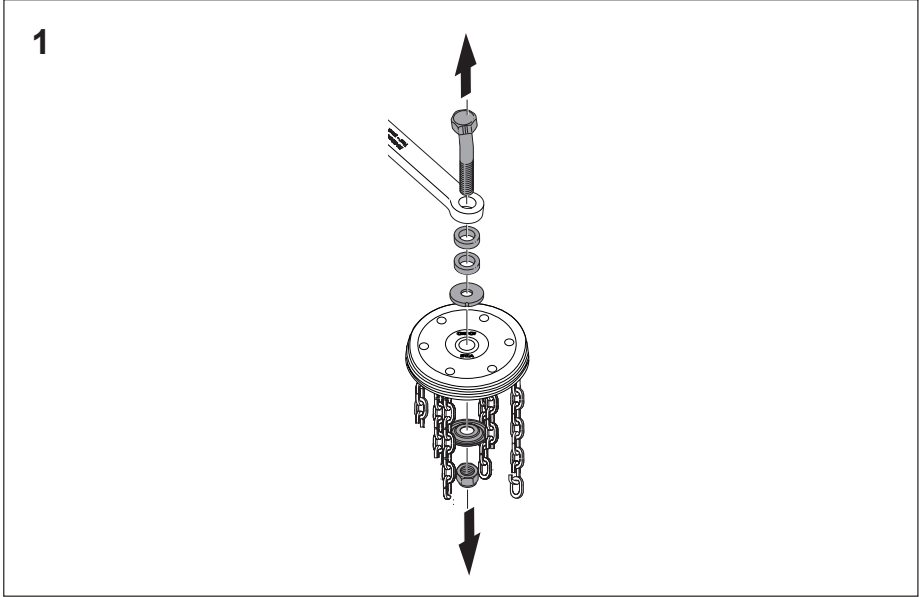
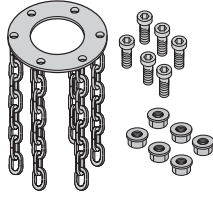

3

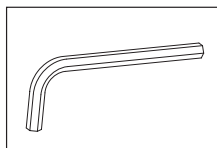
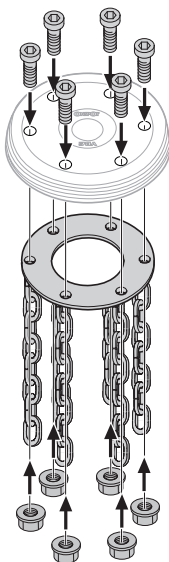

 20 Nm

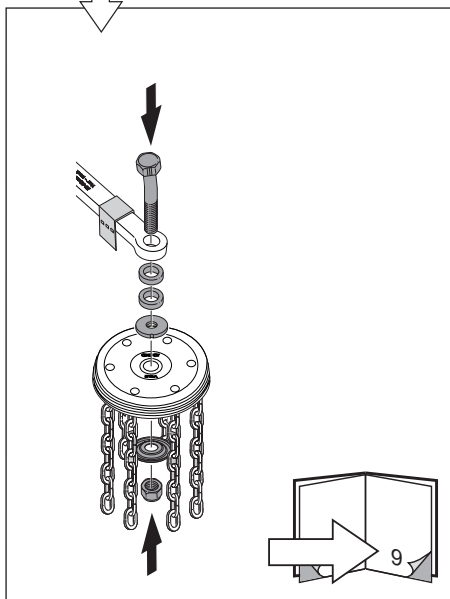
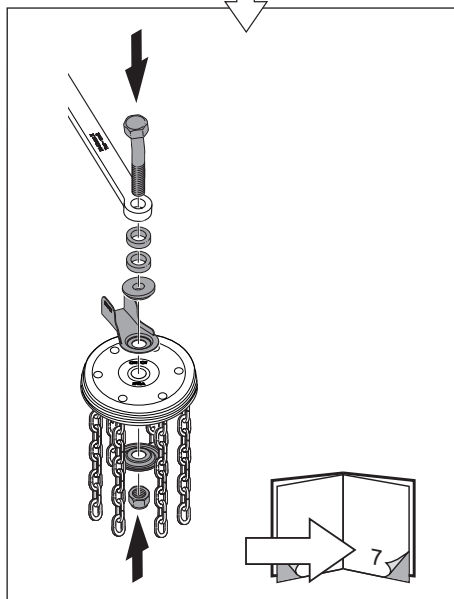
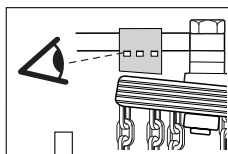
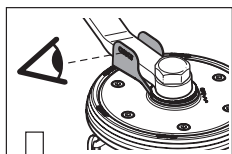

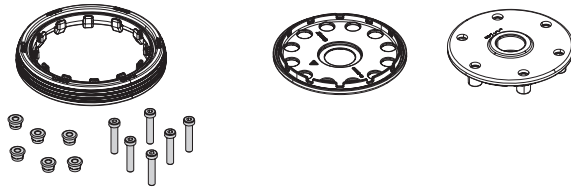



2a

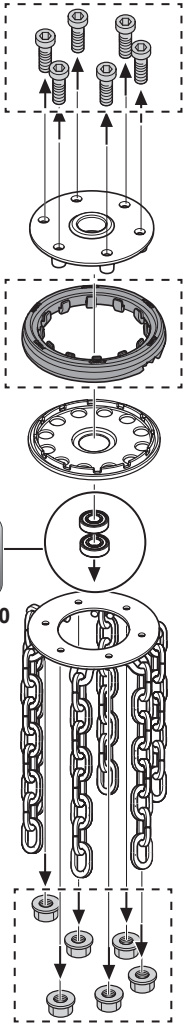
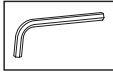

2b

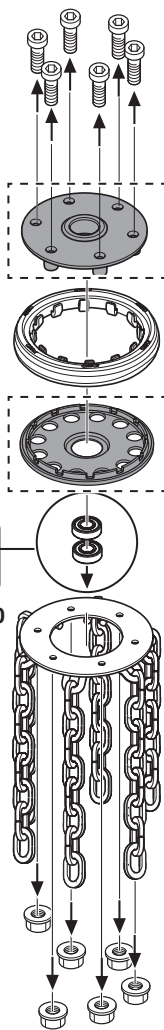
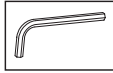

2c

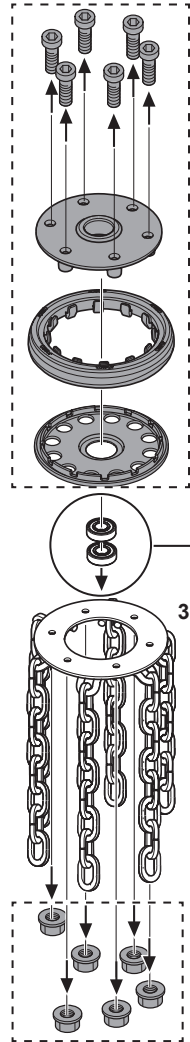
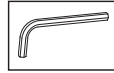



3

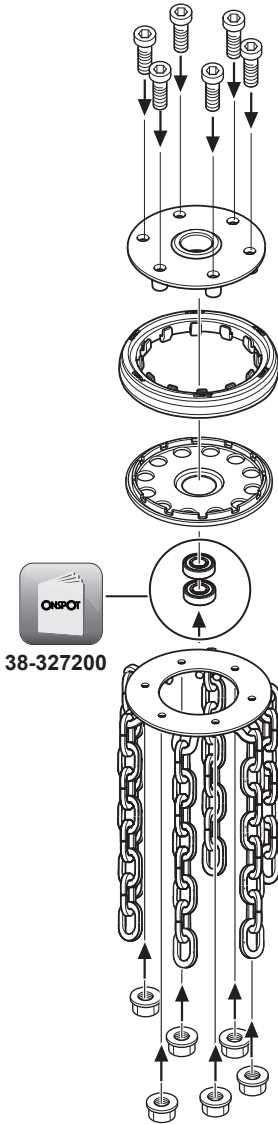
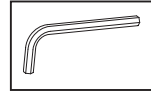

  
20 Nm



